



## Gasdruckfeder

Verwendung als Klappenstütze

## Gas-loaded spring

Application as lid stay

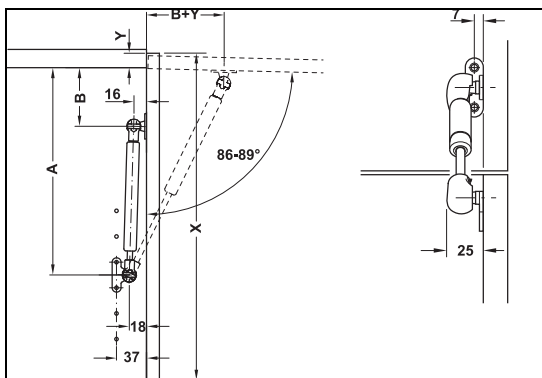

Federkraft N	Länge	Hub	Maß A	Maß B	Artikel- nummer
Spring force N	Length	Lift	Dim. A	Dim. B	Cat. No.
	mm	mm	mm	mm	
60	230	76	231	68	373.78.901
80	230	76	231	68	373.78.902
100	230	76	231	68	373.78.903
100	300	110	295	96	373.78.904
120	300	110	295	96	373.78.905
140	300	110	295	96	373.78.906
125	360	140	359	120	373.78.907
150	360	140	359	120	373.78.908
175	360	140	359	120	373.78.909

## Gasdruckfeder

Verwendung als Deckelstütze

## Gas-loaded spring

Application as chest fitting

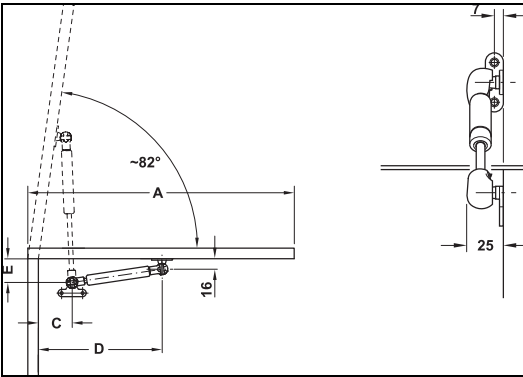

Federkraft N	Länge	Hub	Maß C	Maß D	Maß E	Artikelnummer
Spring force N	Length	Lift	Dim. C	Dim. D	Dim. E	Cat. No.
	mm	mm	mm	mm	mm	
60	230	76	55	215	20	373.78.901
80	230	76	55	215	20	373.78.902
100	230	76	55	215	20	373.78.903
100	300	110	70	275	30	373.78.904
120	300	110	70	275	30	373.78.905
140	300	110	70	275	30	373.78.906
125	360	140	95	320	45	373.78.907
150	360	140	95	320	45	373.78.908
175	360	140	95	320	45	373.78.909

HDE 28.01.2013